

# ThermalAir TA-5000A-HT

An Evolution in Localized Temperature Test Systems



High-Temperature Up To +300°C  
More Technology  
More Control  
More Temperature Capacity  
More Energy Saving

With the MPI Thermal integrated designed architecture, the evolutionary ThermalAir TA-5000A-HT can reach up to +300°C high temperature while saving up to 50% on electricity/ energy/ power!

Extremely low audible noise refrigeration built-in DC Chiller for engineering lab environment

Active temperature control and settable ramp rates for temperature profiling, cycling, thermal shock and testing directly at application on the bench top and production floor

Versatile positioning Boom Arm & Stand compatible with test site pitches and hard to reach applications

Quick & Easy interchangeable temperature head accessories  
[No hardware or tools required]

## Performance Plus! - Productivity!

- Continuous Air Flow up to 25 SCFM @-80°C / +300°C
- -55°C to +125°C / +125°C to -55°C less than 10 sec
- Ultra Stable DC Temperature Control
- Frost Free Operation / Built-in Air Dryer
- No LN<sub>2</sub> or CO<sub>2</sub> Required
- CFC Free / CE Mark

## Flexibility

- Two User Touch Screen Displays on the Head & Front Panel
- USB & SSD Thermal File Management & Data Logging
- Easy Roll Around wheels for portability
- Plug-in Anywhere 185 to 250 VAC, 50/60Hz  
[No configuration required]



# ThermalAir TA-5000A-HT

## Temperature Conditioning System

# Specifications

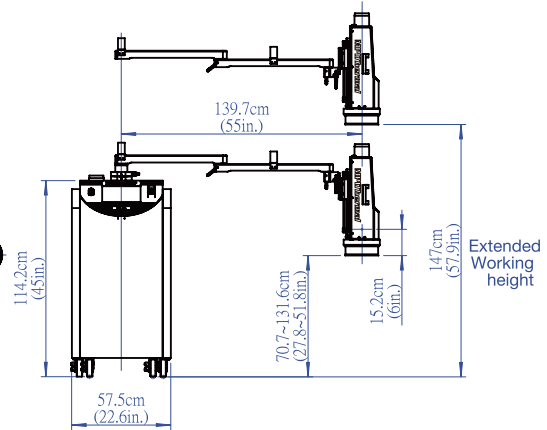
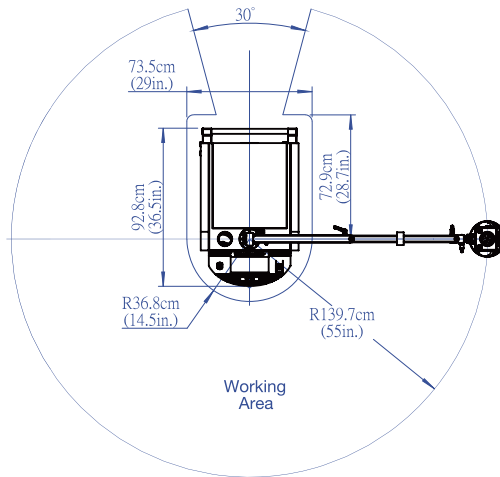

### Full Interface For All Communication Control Requirements

4 USB-Type A, 1 USB-Type B, HDMI, IEEE-488, LAN, RS-232, T-Type, K-Type and RTD temperature sensors PLUS Auto Start Test & End of Test for automatic temperature cycling Hot-Cold-Amb.

All these are made for simple control and serviceability.



MPI Thermal TA-5000A-HT  
A Division of MPI Corporation

## Specifications

### Temperature Performance & Airflow Capacity

Temperature Range	-80°C to +300°C (50/60Hz same system, same temperature performance)
Typical Temperature Transition Rate	-55°C to +125°C / +125°C to -55°C <10 sec
Temperature Accuracy	± 1.0°C (calibrated system)
Temperature Resolution	± 0.1°C
Temperature Air Output System	4 to 25 SCFM (1.9 to 11.8 l/s) Continuous
Temperature Control Methods	Environmental Internal Air TC and Remote External Type T, K, RTD (TC Sensors)

Note: Systems DO NOT degrade @50Hz or @High Air Flow Output Rates

### Facility Requirements / Dimensions & Weights / Compressed Air

Base Unit & System Weight	W=57.5cm (22.6in.), D=92.8cm (36.5in.), H=136.3cm (55.7in.) Un-packed: 265kg (584 lbs) / Packed: 395kg (870 lbs)
Portability	Static dissipative, four easy roll swivel caster wheels
Maximum Reach	139.7cm (55 in.)
Maximum & Minimum Heights	Standard: 70.6-131.6cm (27.8-51.8in.) / Extended: 85.9-146.9cm (33.8-57.9in.)
Hi-Temp Accessories	5.7 inch HT Metal Cap; 4 ft. HT Flex Extender Hose
Noise Level	<49 dBA average
Power	185 - 250VAC (220 Nominal), 60 / 50Hz, 30amp, 1 phase
Clean, Dry Air (CDA)	Filtered to 5µ particulate contamination Oil Content: < 0.10 ppm by weight and filtered to 0.01µ oil contaminants
Input Air Dewpoint	+10°C dewpoint or dryer@90PSI (6.2 BAR)
Input Air Pressure	90 to 120 PSIG (6.2 to 8.3 BAR)
Input Air Flow	15 to 30 SCFM (7.2 to 14.3 l/s) 25 SCFM nominal
Input Air Temperature	+15° to +25°C, +22°C nominal
Operating Temperature Environment	+15° to +28°C, +23°C nominal
Operating Humidity	0 to 60% RH, 45% nominal

Temperature Solutions **MPI Thermal** For The Future

A Division of MPI Corporation

Email: info@mpi-thermal.com | Web: www.mpi-thermal.com