

# ThermalAir TA-3000A

## An Evolution in Localized Temperature Test Systems

**More Technology**

**More Control**

**More Temperature Capacity**

**More Energy Saving**



### Performance Plus! - Productivity!

- Continuous air flow up to 16 SCFM @-60°C / +225°C
- -40°C to +125°C / +125°C to -40°C in less than 10 sec
- Ultra Stable DC Temperature Control
- Frost Free Operation/ Built-in Air Dryer
- No LN<sub>2</sub> or CO<sub>2</sub> Required
- CFC Free/ CE Mark

### Flexibility

- Built-in color touch screen display GUI
- USB & SSD Thermal file management & data logging
- Easy roll around wheels for portability
- Plug-in anywhere 200 to 250VAC, 50/60Hz  
[ No configuration required ]

Unique architecture of the **ThermalAir TA-3000** creates unprecedented performance while saving up to 50% on electricity/energy/power!

- Extremely low audible noise refrigeration built-in DC chiller for engineering lab environment
- Active temperature control and settable ramp rates for temperature profiling, cycling, thermal shock and testing directly at application on the bench top and production floor
- Versatile positioning boom arm & stand compatible with test site pitches and hard-to-reach applications
- Quick & easy interchangeable temperature head accessories [No hardware or tools required]

# ThermalAir TA-3000A

## Temperature conditioning System

# Specifications

### Dimensions

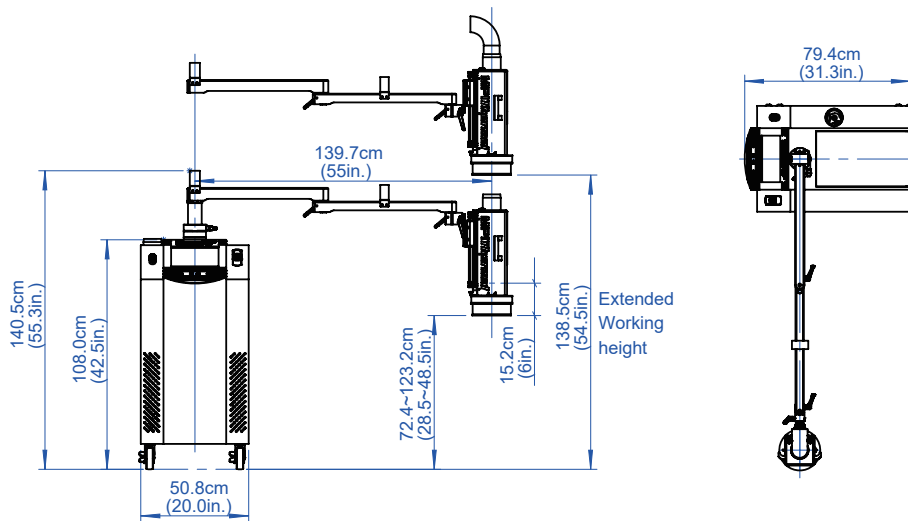

### Full inline interface for all communication control requirements

3 USB-Type A, 1 USB-Type B, IEEE-488, LAN, RS-232, T-Type, K-Type and RTD temperature sensors PLUS Auto Start Test & End of Test for automatic temperature cycling Hot-Cold-Amb. All these are made for simple control and serviceability.

## Specifications

### Temperature Performance & Airflow Capacity

Temperature Range	-60°C to +225°C (50/60Hz same system)
Typical Temperature Transition Rate	-40°C to +125°C / +125°C to -40°C <10 sec
Temperature Accuracy	± 1.0°C (calibrated system)
Temperature Resolution	± 0.1°C
Temperature Air Output System	5 to 16 SCFM (2.4 l/s to 7.5 l/s) Continuous
Temperature Control Methods	Environmental Internal Air TC and Remote External Type T, K, RTD (TC Sensors)

Note: Systems DO NOT degrade @50Hz or @High Air Flow Output Rates

### Facility Requirements / Dimensions & Weights / Compressed Air

Base Unit & System Weight	W=50.8cm (20.0in.), D=79.4 cm (31.3in.), H=140cm (55.3in.) Un-packed: 230kg (506 lbs) / Packed: 310kg (683 lbs)
Portability	Static dissipative, four easy roll swivel caster wheels
Maximum Reach	139.7cm (55 in.)
Maximum & Minimum Heights	Standard: 72.4-123.2cm (28.5-48.5in.) / Extended: 87.7-138.5cm (34.5-54.5in.)
Hi-Temp Glass Cap Enclosures	5.5 inch I.D., Standard. Optional sizes available
Noise Level	<52 dBA average / Full performance at 50 Hz operation
Power	System operates both at 50Hz & 60Hz 200 - 250VAC (220 Nominal), 60 / 50Hz, 20amp, 1 phase

### Compressed Air

Clean, Dry Air (CDA)	Filtered to 5µ particulate contamination Oil Content: < 0.10 ppm by weight and filtered to 0.01µ oil contaminants
Input Air Dewpoint	+10°C dewpoint or dryer@90PSI (6.2 BAR)
Input Air Pressure	90 to 120 PSIG (6.2 to 8.3 BAR)
Input Air Flow	11 to 26 SCFM (5.2 to 12.3 l/s) 21 SCFM nominal
Input Air Temperature	+15° to +25°C, +22°C nominal
Operating Temperature Environment	+15° to +28°C, +23°C nominal
Operating Humidity	0 to 60% RH, 45% nominal

MPI Thermal ThermalAir TA-3000A  
A Division of MPI Corporation